

# SIX STEP, ALUMINUM, CROSS OVER - COL-AL-6-56-23

APPROX WEIGHT: 184.78 lbs.  
 DOES NOT INCLUDE WEIGHT OF POWER OR PACKAGING!!!

\*\*\* ANY ADDITIONS, DELETIONS, OR OMISSIONS MUST BE CORRECTED ON THIS DRAWING AS THIS DRAWING WILL BE CONSIDERED ALL INCLUSIVE \*\*\*  
 ALL GRAPHICS PROVIDED ARE FOR REFERENCE ONLY. IF CERTAIN DIMENSIONS ARE CRITICAL PLEASE VERIFY THOSE DIMENSIONS WITH YOUR SALESPERSON

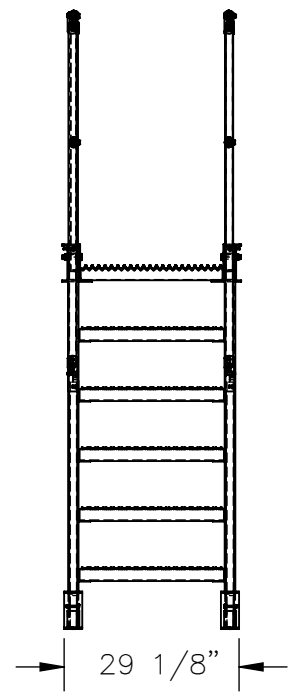
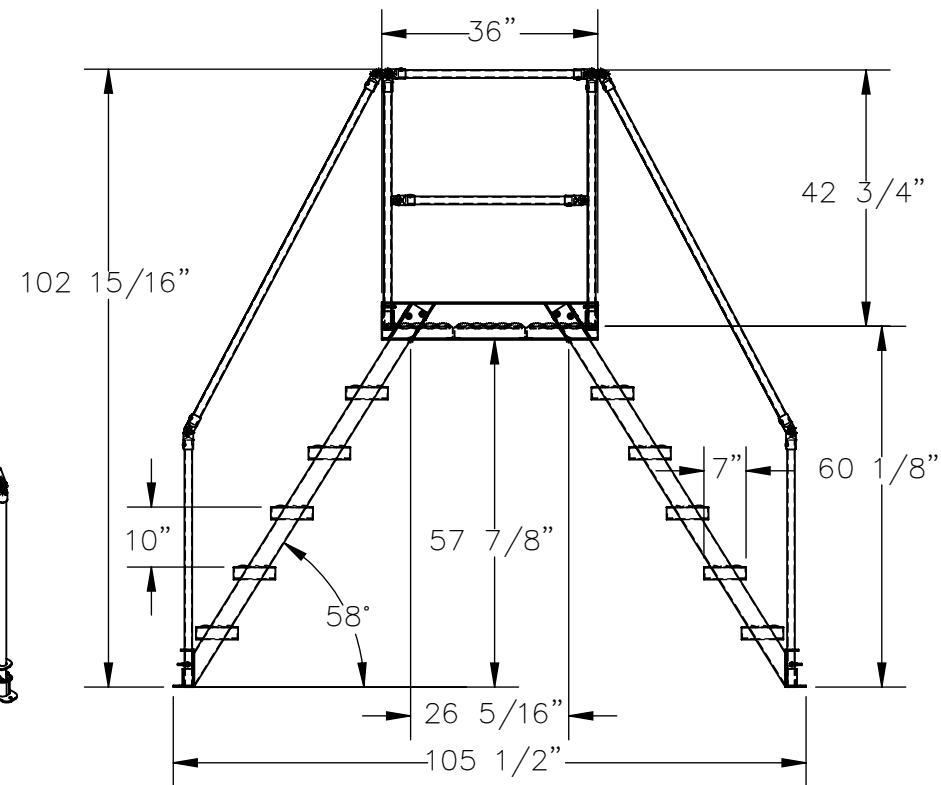
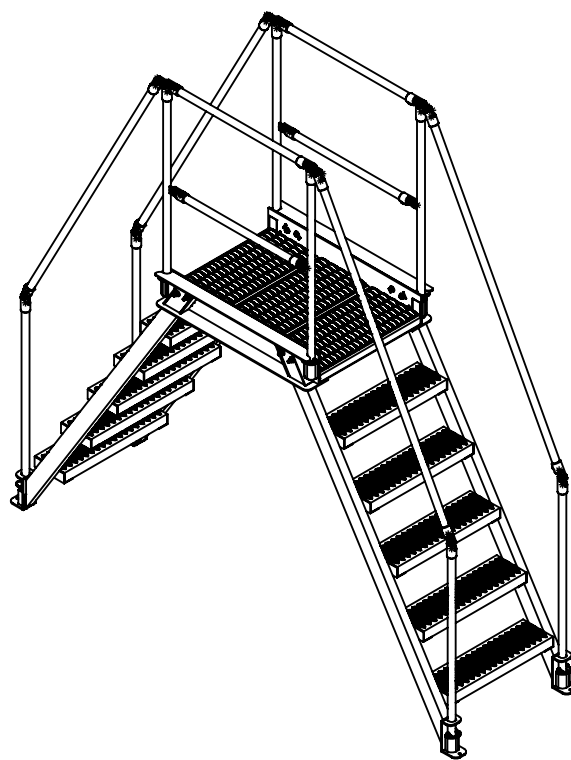

DIMENSION TOLERANCE ± 1/4"

**STANDARD FEATURES:**  
 MODEL NUMBER: COL-AL-6-56-23  
 OVERALL SIZE  
 29 1/8" x 105 1/2"L x 102 15/16"H  
 CLEARANCE SPAN:  
 26 5/16"W x 57 7/8"H  
 TOP PLATFORM HEIGHT: 60 1/8"  
 STEP HEIGHT SPACING: 10"  
 STEP DEPTH: 7"  
 STEP & PLATFORM WIDTH: 29 1/8"  
 CLIMB ANGLE: 58°  
 ALUMINUM CONSTRUCTION

**SPECIAL FEATURES:**  
 NONE

**A P P R O V A L**

I, THE UNDERSIGNED, AGREE THAT THE PRODUCT AS REPRESENTED SATISFIES DESIGN AND DIMENSION REQUIREMENTS. I ALSO ACKNOWLEDGE MY DUTY TO CONFIRM PRODUCT AND INSTALLATION COMPLIANCE WITH ALL APPLICABLE FEDERAL, STATE AND LOCAL REGULATIONS AND STANDARDS.

**UNITS REQUIRING APPROVAL DRAWINGS OR MODIFIED ARE NON-RETURNABLE**

As drawn       As marked

Signed: \_\_\_\_\_ Date: \_\_\_\_\_

Printed Name: \_\_\_\_\_

*LEAD TIME WILL START UPON RECEIPT OF SIGNED APPROVAL DRAWING*

DISTRIBUTOR'S NAME:		P.O.#
VESTIL MANUFACTURING		X
DRAWN BY: T. HARKRADER		W.O.#
DATE: 8/25/21		X
REFERENCE: X	SCALE: 1:32	SALES: X
QUOTED LEAD TIME: X	QUOTE #	FILE NAME:
	X	44-007-782